



Jezersko

kako prepoznati, ohranjati in živeti s tradicijo

katalog ograj

januar 2019





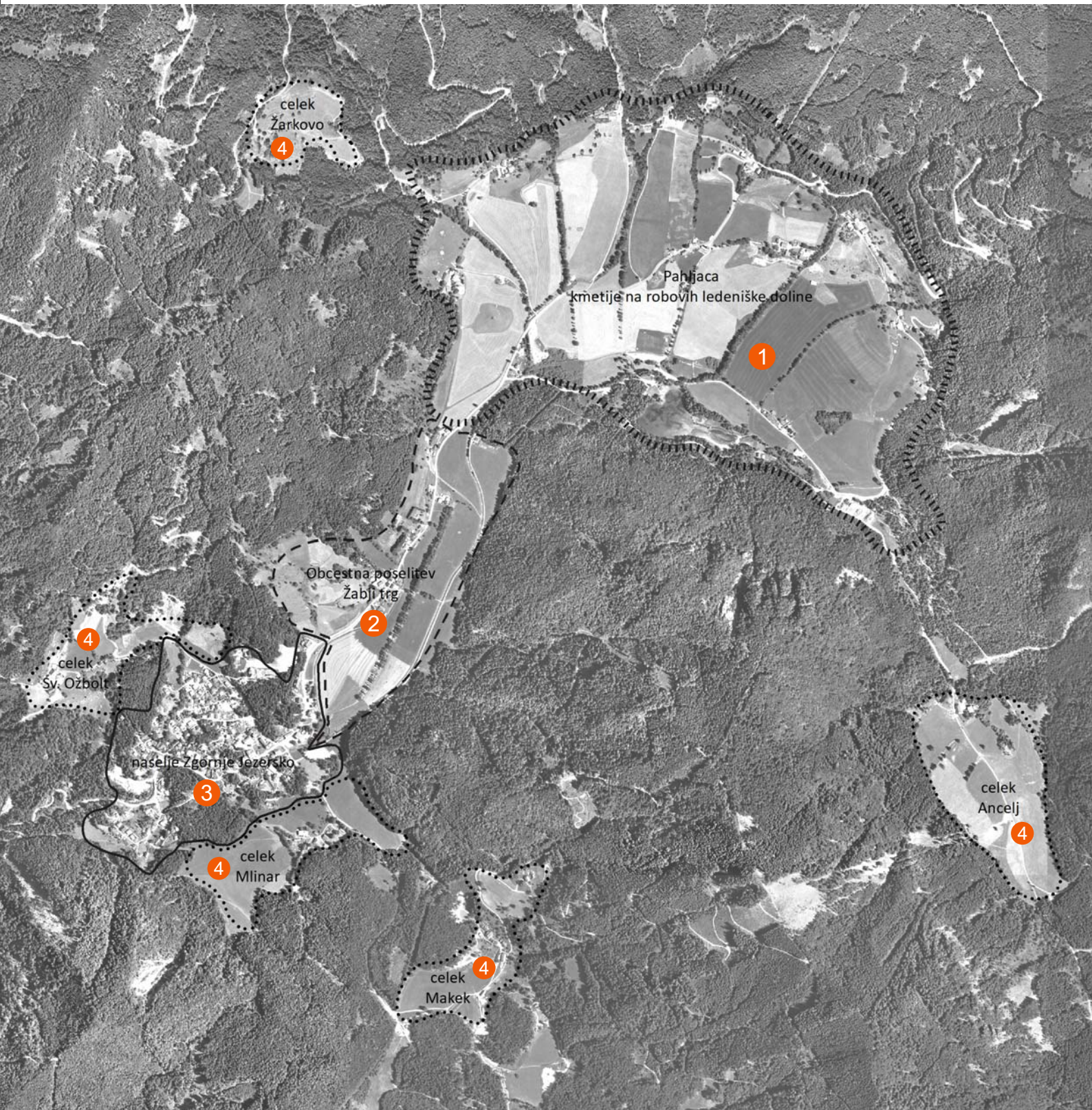

V katalogu se določa izključno oblikovanje objektov, ki so predmet tega kataloga in ne dopustnosti gradnje le teh. Dopustnost gradnje na posameznih območjih določa veljavni prostorski akt.

V katalogu so v skladu s strokovno podlago za kulturno krajino določena območja poselitve, ki imajo skupne značilnosti glede oblikovanja objektov iz tega kataloga.

Ob vsakem objektu je zapisana številka, ki določa na katerem območju je predlagano oblikovanje dopustno. Na drugih območjih tako oblikovanje objektov ni dopustno. V primeru, da je za posamezen objekt določena posebnost glede oblikovanja, je le ta zapisana ob samem objektu.

V katalogu so prikazani principi oblikovanja objektov. Grafični primer se uporablja kot podlaga za projektiranje objektov.

Dopustna so odstopanja pri oblikovanju ograj:
- končna obdelava lesa (npr. okroglica ali krajnik namesto ploha)

legenda

- 1 kmetije in poselitev v ledeniški dolini
- 2 obcestna poselitev
- 3 naselje Zgornje Jezersko in preostali del občine
- 4 kmetije na izravninah terena



Fotografija: Saša Štuhec



ograje

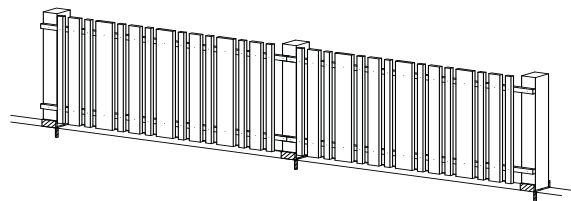
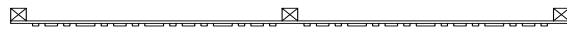
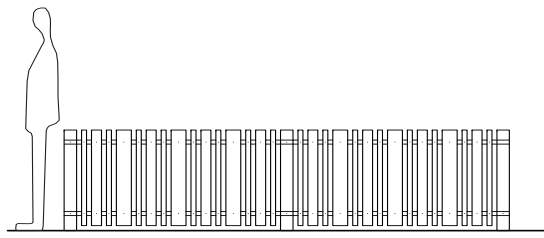
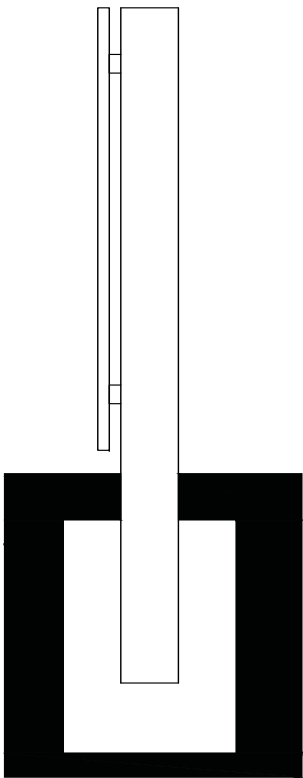

ograja št. 1 3

nadzemni del: les (nebarvan in brez uporabe lazurnih premazov)

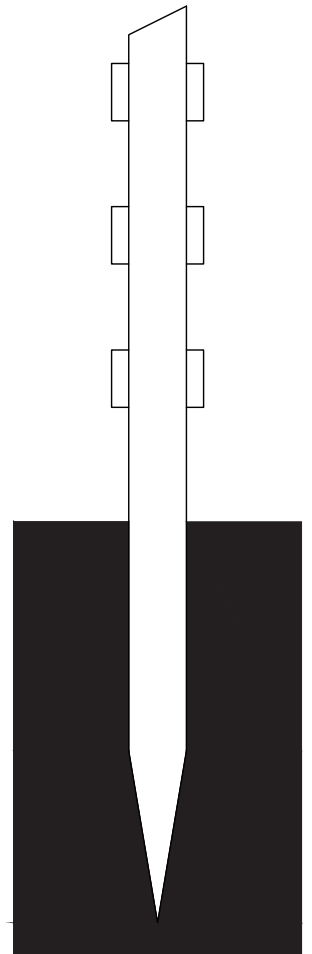
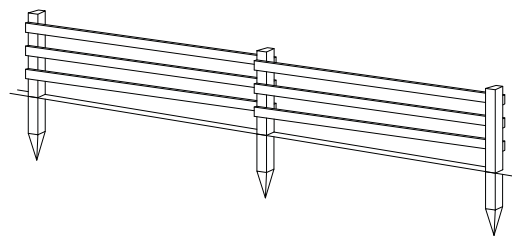
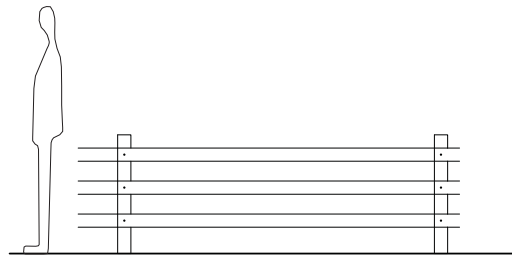
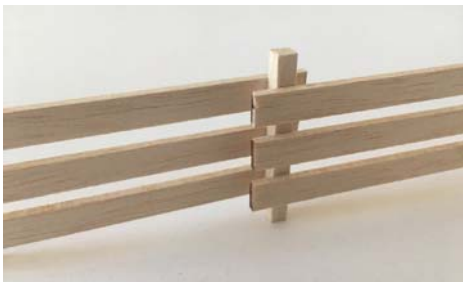
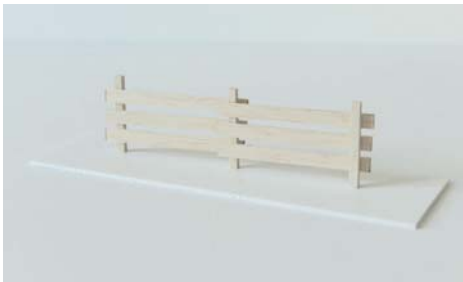

ograja št. 2 1 2 3 4

nadzemni del:
les (nebarvan in brez uporabe lazurnih premazov)

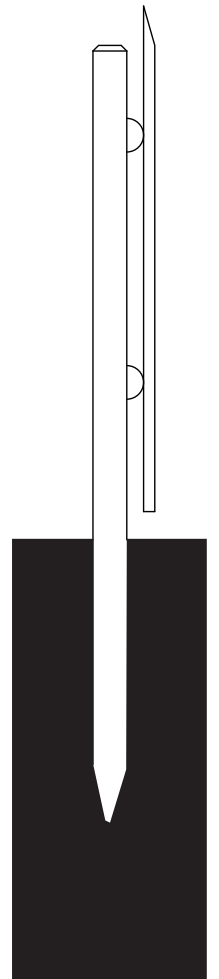
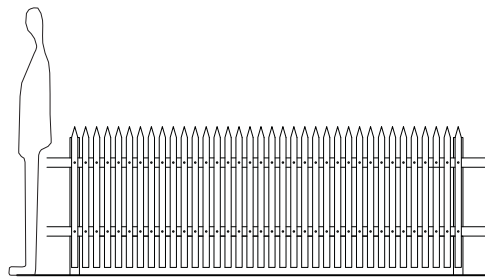
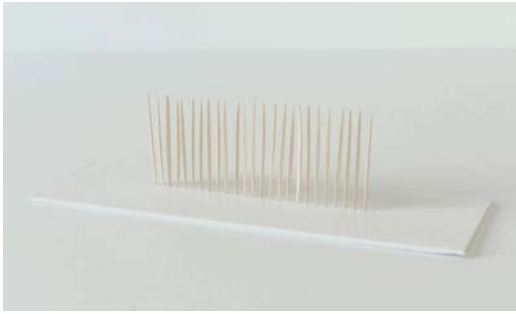

ograja št. 3 1 2 3 4

nadzemni del:

les (nebarvan in brez uporabe lazurnih premazov)

umeščanje: samo ograja za zelenjavne vrtove,
v naselju (3) je možno tudi kot ograjevanje parcel

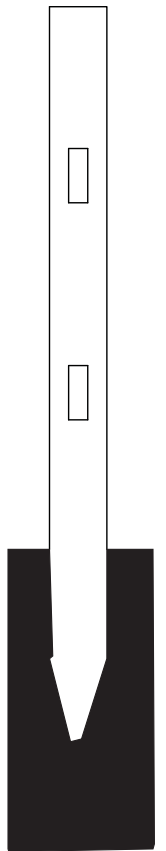
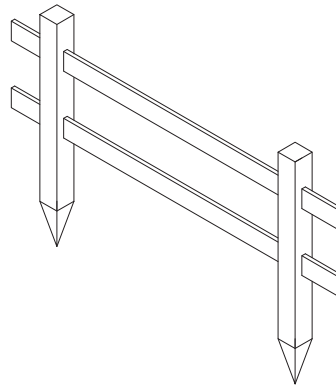
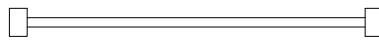
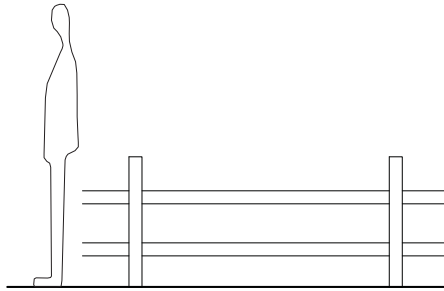
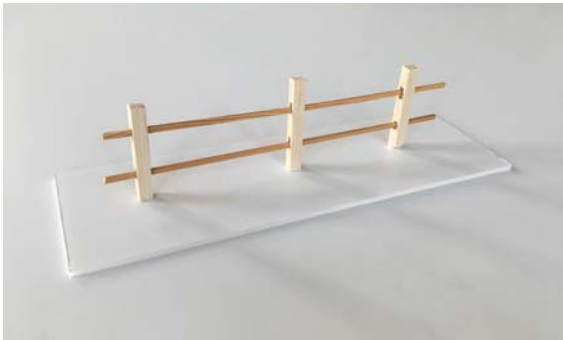
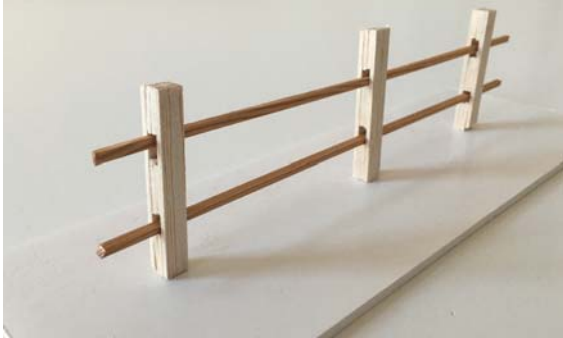

ograja št. 4 1 2 3 4

nadzemni del:
les (nebarvan in brez uporabe lazurnih premazov)

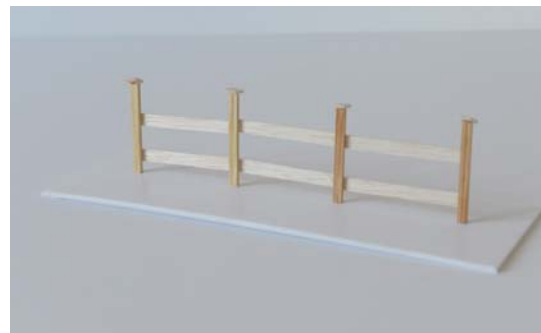
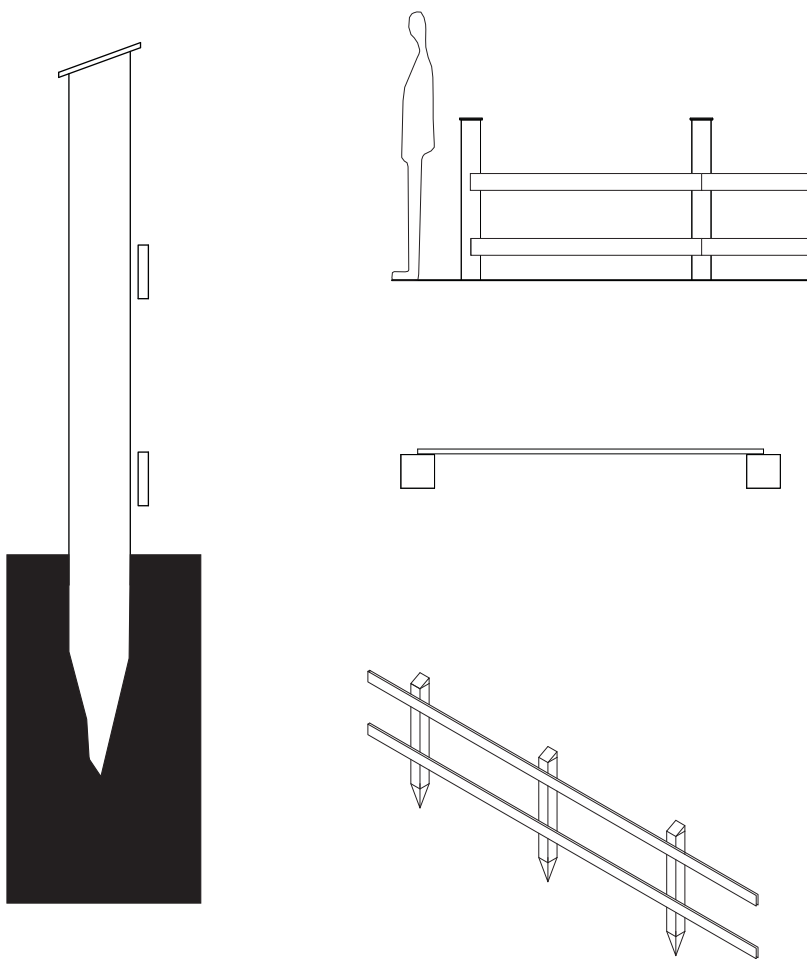

ograja št. 5 1 2 3 4

nadzemni del: les (nebarvan in brez uporabe lazurnih premazov)

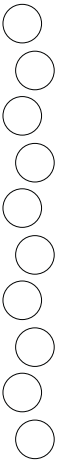
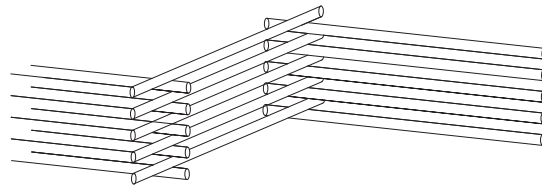
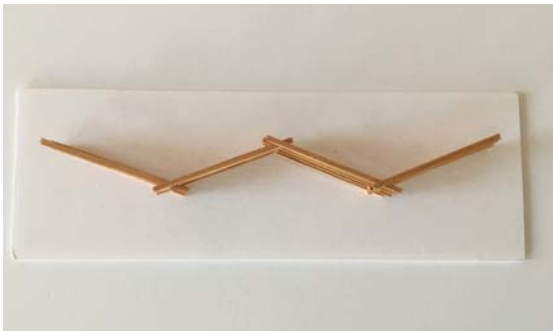
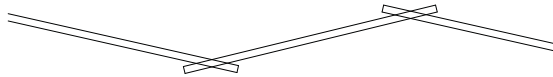
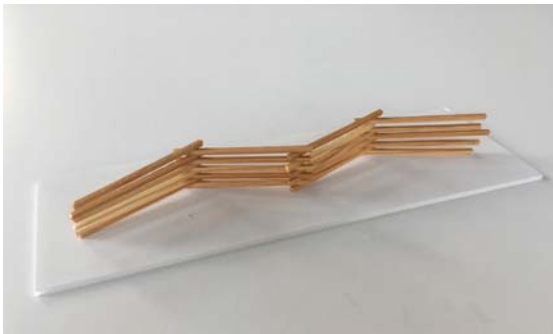
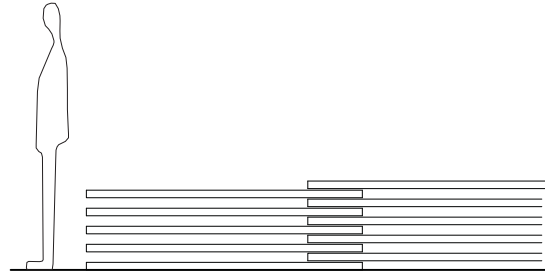

ograja št. 6 3

nadzemni del:

les (nebarvan in brez uporabe lazurnih premazov)

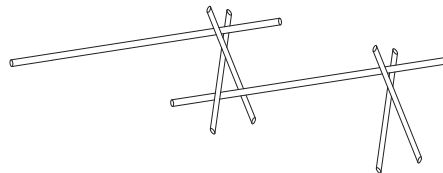
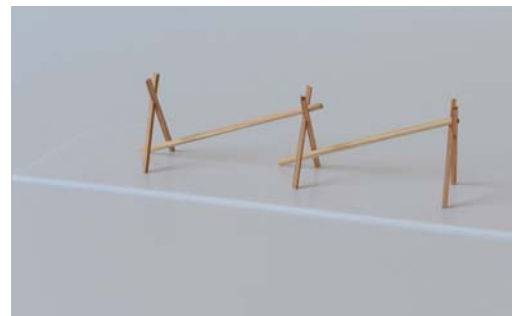
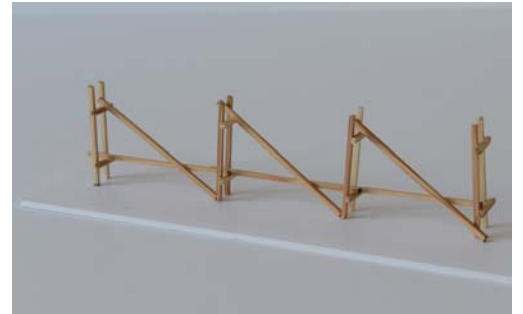
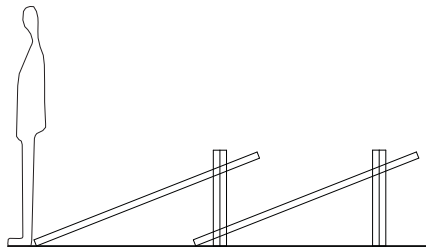
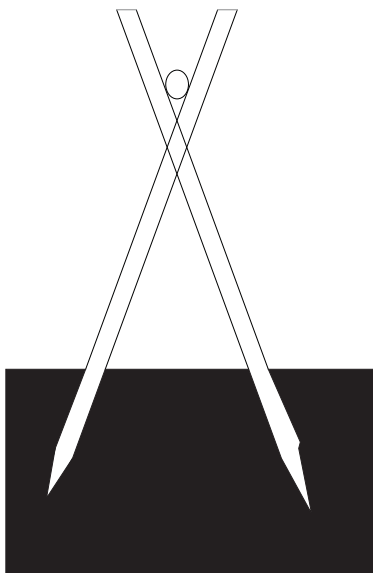

ograja št. 7 1 4

nadzemni del: les (nebarvan in brez uporabe lazurnih premazov)

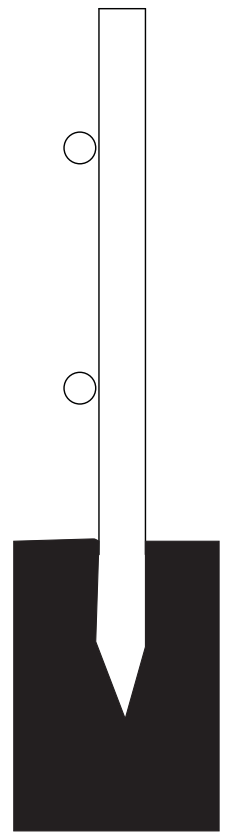
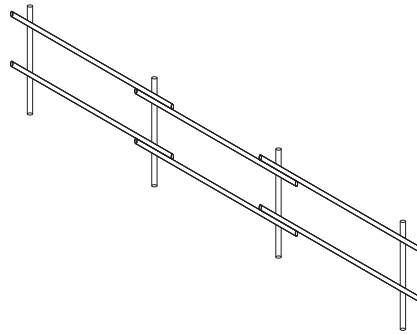
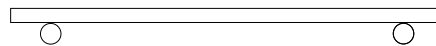
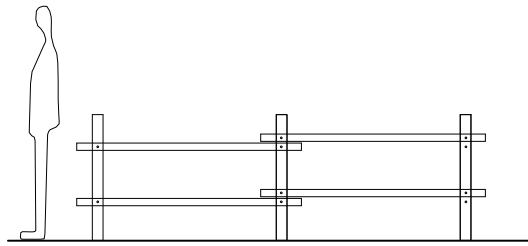

ograja št. 8 **1 2 4**

nadzemni del:

les (nebarvan in brez uporabe lazurnih premazov)

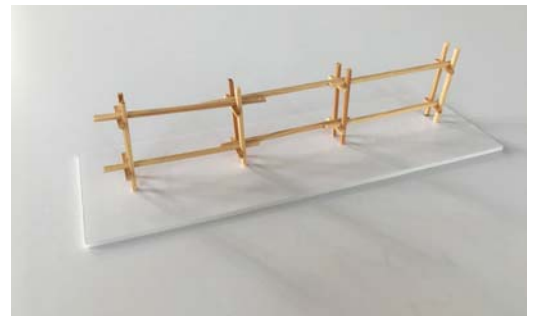
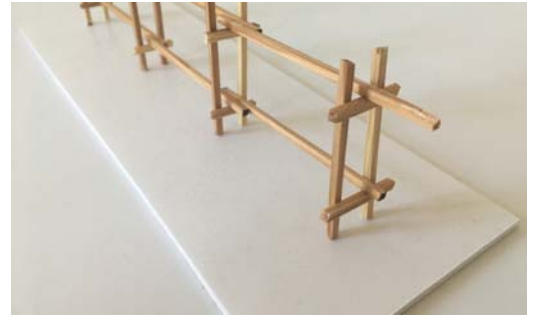
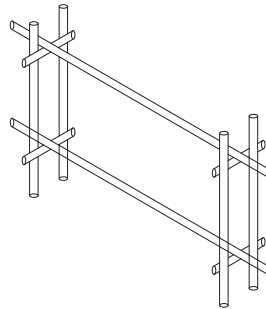
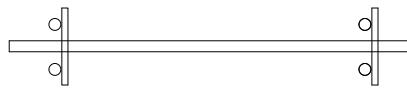
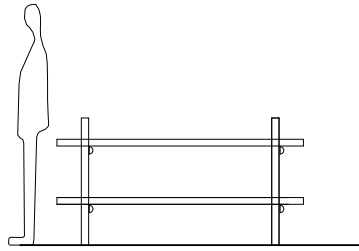
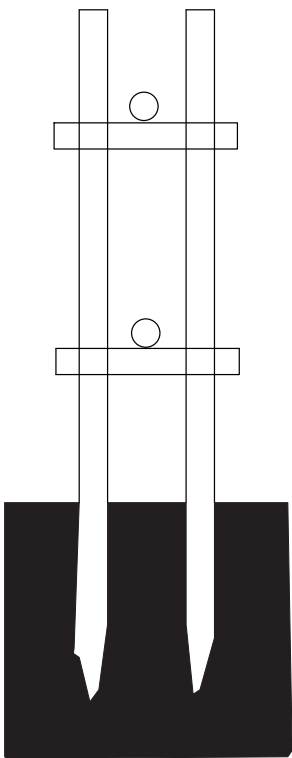

ograja št. 9 **1 2 3 4**

nadzemni del: les (nebarvan in brez uporabe lazurnih premazov)